

Rev.	ECN No.	Revision note.	Date	Revised by
------	---------	----------------	------	------------

Tolerance on overall length(OAL).			
Nominal size	up to 100A	125A to 400A	450A to 1000A
up to 500	±3	±4	±6
501 to 1000	±4	±5	±8

Refer. DIN EN 14917:2012-06

FLANGE TYPE		
TYPE OF FLANGE	FF	RF
STANDARD FLANGE	●	●
JIS 5K	●	
JIS 10K	●	
JIS 20K		●
PN 10	●	
PN 16		●
PN 25		●
ANSI150		●
ANSI300		●

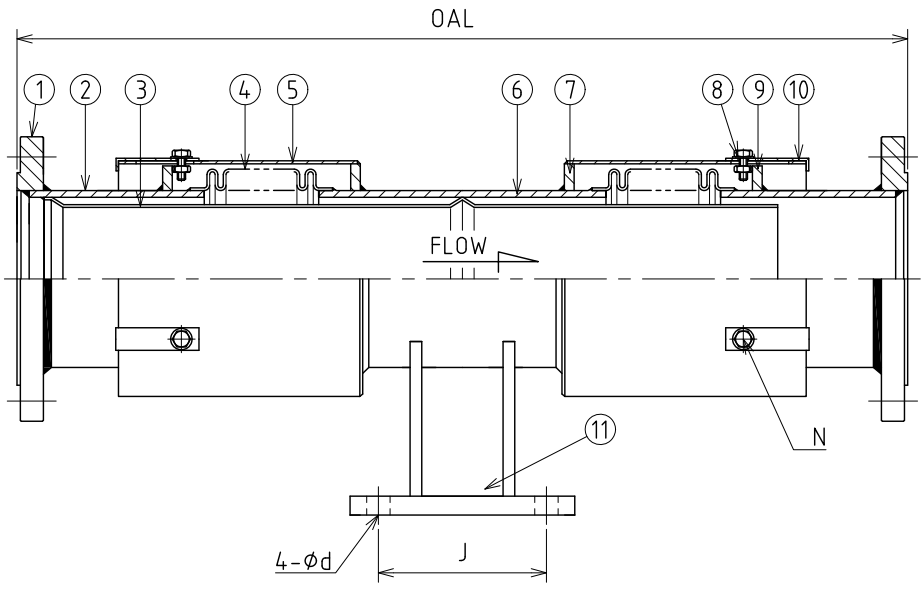
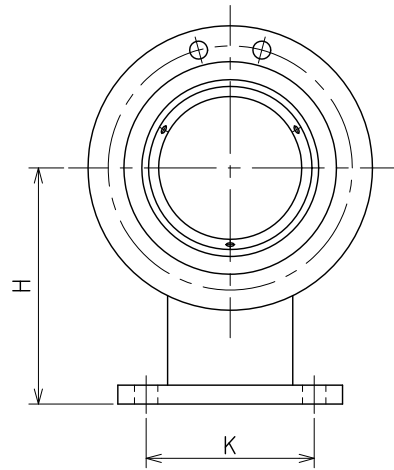

No.	SIZE mm(inch)	OAL (mm)	DESIGN PRESSURE (bar)	DESIGN TEMP (Deg C)	AXIAL MOVEMENT(mm.)	H	J	K	φd	N (Set)
1	40A(1.1/2")	680	10	250	50	120	100	70	12	4
2	50A(2")	680	10	250	50	130	100	80	15	4
3	65A(2.1/2")	780	10	250	70	140	120	100	15	4
4	80A(3")	780	10	250	70	150	120	110	15	4
5	100A(4")	880	10	250	70	170	120	130	19	6
6	125A(5")	880	10	250	70	200	120	150	19	6
7	150A(6")	930	10	250	70	220	160	180	23	6
8	200A(8")	930	10	250	70	250	160	220	25	8
9	250A(10")	980	10	250	70	300	180	280	27	8
10	300A(12")	980	10	250	70	350	200	300	27	8
11	350A(14")	1030	10	250	70	450	250	350	33	8
12	400A(16")	1030	10	250	70	500	300	400	33	8
13	450A(18")	1080	10	250	70	550	350	450	39	8
14	500A(20")	1080	10	250	70	600	400	500	39	8

Note : - Holes on flange may not shown the number in fact.
 - Any information provided in drawing is subject to change without notice for error rectification or design modification.

Item	Part Name	Material	Q'ty	Remark
11	ANCHOR BASE	SS400/SUS304	1 SET	
10	CLAMP PLATE	SS400/SUS304	N	TO BE REMOVE AFTER INSTALLATION
9	RING 2	SS400/SUS304	2	
8	SHIPPING BOLT, NUT, WASHER	SS400/SUS304	N	
7	RING 1	SS400/SUS304	2	
6	MIDDLE PIPE	CS/SUS304/SUS316	1	
5	COVER	SS400/SUS304	2	
4	STAINLESS STEEL BELLOW	SUS304/SUS316L	2	
3	INNER SLEEVE	SUS304/SUS316L	1	WITH DRAIN HOLES
2	SHORT PIPE	CS/SUS304/SUS316	2	
1	FIXED FLANGE	SS400/SUS304/SUS316	2	JIS10K, ANSI150, PN10

Wellgrow Industrial Estate
Chachoengsao, Thailand
www.tozen.co.th

PROPRIETARY DATA

THIS DOCUMENT CONTAINS TOZEN INDUSTRIAL CO.,LTD. CONFIDENTIAL AND PROPRIETARY INFORMATION AND CANNOT BE USED, DUPLICATED OR DISCLOSED IN WHOLE OR IN PART EXCEPT WITH EXPRESS WRITTEN PERMISSION OF TOZEN INDUSTRIAL CO.,LTD.

DATE	DRAWN BY	CHECKED BY	APPROVED BY	TITLE	EXPANSION JOINT,SJT-2200	Revision	Size
20/11/2017	PRATUENG T.	WUTHIPAN	SOMKRITSADA	DWG NO.	MTE-18-012-00	00	A4
				MATERIAL	See in Table	SCALE : N.T.S	UNIT : mm
						Method	